

Operation Manual

 **AQUA MEDIC**
Turboflotor 5000
SHORTY COMPACT

Protein skimmer for aquariums up to 1500 litres (400 Gallons)

Powerful skimmers for in cabinet installation.

With the purchase of this protein skimmer you have selected a top quality product. It has been specifically designed for aquarium use and tested by professionals.

This unit will effectively remove organic substances from your aquarium water.

1. Basics

During the protein skimming process organic pollutants in the aquarium water, i.e. protein compounds formed by the excretions of animals, are attached to fine air bubbles as a monomolecular film. These air bubbles are pushed against the inflowing water in the reaction pipe so that there is a long contact time. Enriched with organic substances, they rise to the top and form a strong foam which is dehydrated in the reaction pipe and then passes into the collection cup.

Using this method, removal of organic pollutants from the aquarium water takes place, whereas during bacterial processes they are merely transformed and not removed.

2. Product description

The *Turboflotor 5000* consists of:

- reaction pipe, 200 mm (8 inch) diameter and bayonet socket
- conical collection cup
- venturi pump **OCEAN RUNNER 3500** with **AQUA MEDIC** needle wheel
- two large outlet ports (40 mm)
- inlet with hose tail connection (20 mm)
- drain ball valve at the base of the skimmer with hose tail connection (25 mm)
- air tube for the venturi pump.

1. Top lid
2. Foam cup
3. O-ring
4. Reaction pipe
5. Water inlet
6. Outlet fittings
7. Adrusion valves
8. Needle wheel pump
9. Needle wheel impeller
10. air injection nozzle with connection for air tube

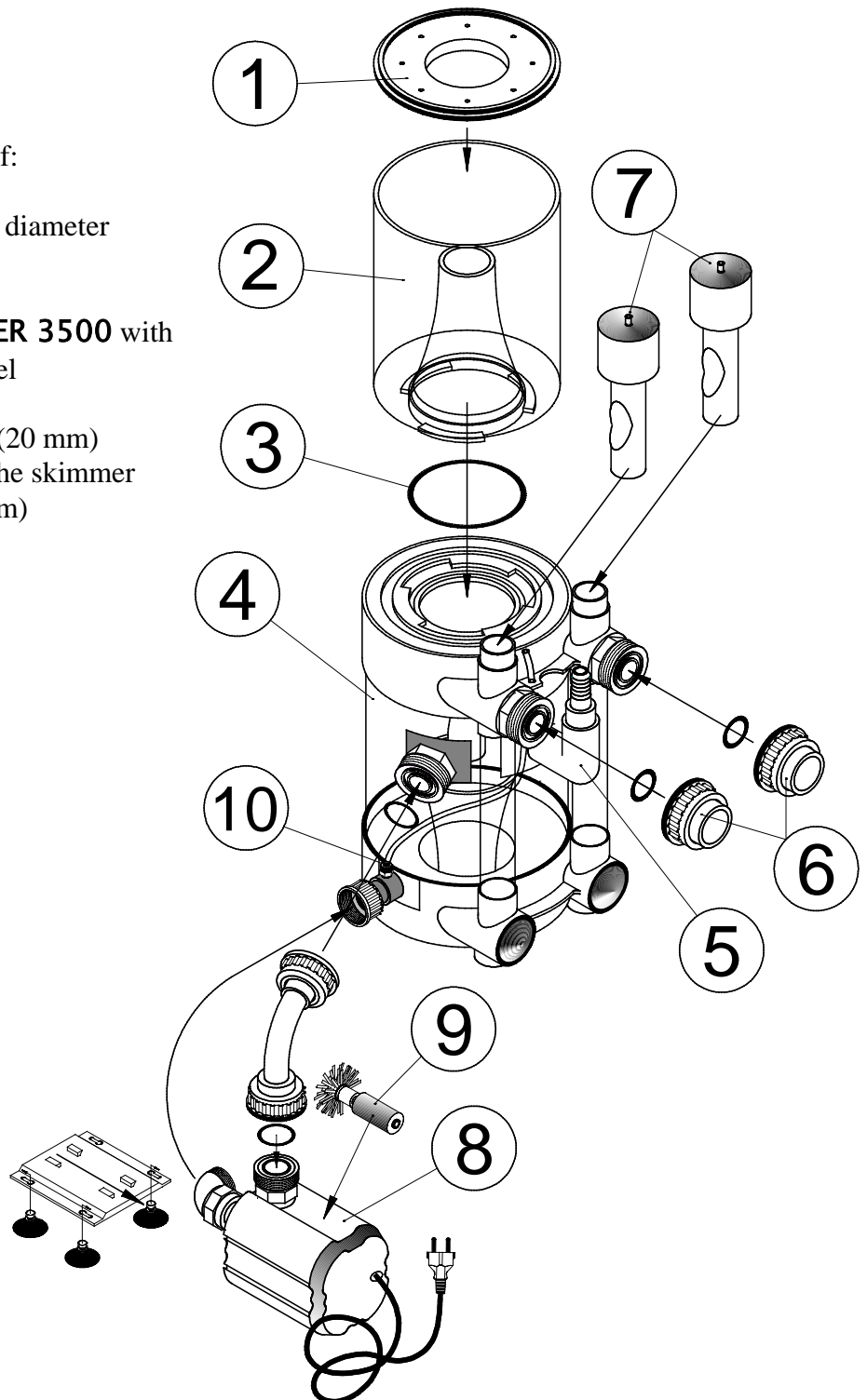

Type	Outlet height	Total height	Venturi pump	Power consumption	Capacity
Turboflotor 5000 SHORTY COMPACT	30.5 cm (12")	62 cm (25")	OCEAN RUNNER 3500 with needle wheel	65 Watts	up to 1,500 l 400 Gallons

3. Principle of Operation

The aquarium water is pumped to the skimmer using a separate pump (not supplied) which should have a capacity of approx. 2,000-4,000 litres/hour. The relative positions of the inlet and outlet ports ensures the maximum contact time of the air bubbles in the counter current. If the **SHORTY COMPACT** is mounted in the cabinet, it can be supplied with water directly from the overflow of the aquarium. In this case a bypass should be installed, so the volume of water can be adjusted

The venturi pump draws the water from the skimmer and mixes it with air. Within the pump housing the bubbles are cut into very fine pieces by the  **AQUA MEDIC** needle wheel. The air/water mixture is pumped back into the skimmer.

The treated water flows out of the bottom of the skimmer and is pumped through the two transparent pipes positioned outside the skimmer back into the aquarium or filter sump.

4. Installation

- Check that the sealing rings for the unions are in place.
- Slot the holding plate for the venturi pump to one side of the skimmer. Push the pump on to the holding plate and connect the pump to its union.

The PVC air tube should be fed so, that the end is higher, than the water level in the skimmer. **This air tube must not hang down.** It should only jut out 5 cm at the top.

Connect the bottom end of the tube to the air intake of the pump.

- The water inlet is located at the same side as the outlet pipes. Attach the union and the hose tail (20mm).
- We recommend a pump with a capacity of 2,000 to 4,000 litres/hour for the water supply or direct connection to the aquarium overflow.

- Fit the rubber sealing ring for the bayonet socket of the reaction pipe.

Push the foam cup into its seating and turn it to lock.

The drain from the skimmer has to run freely into the aquarium. A PVC pipe (40 mm dia) can be glued into the drain ports. It is possible to let both drains flow into one pipe, but the diameter of the pipe must not be reduced. If the drains are left separate, a reduction in pipe size to 32mm is possible.

The skimmer can now be filled by pumping directly from the aquarium. Ensure that the water level of the aquarium is not lowered too much. As soon as the water level in the skimmer reaches the height of the venturi pumps, these pumps should be started.

Top up with sea water as necessary.

After first use or after cleaning of the skimmer it takes some time for the initial foam to build up in the reaction pipe of the collection cup. This is because the cleaned acrylic initially reacts with the water until a build up of fatty acids naturally takes place.

After approx. 24 hours, the foam should be pushed slowly and evenly into the collection cup. The quantity of liquid and organic substances depends on the pollution of the aquarium.

5. Maintenance

- **Collection cup:** Depending on the organic load the cup should be cleaned daily to weekly.
- **Reaction pipe:** This needs to only occasional cleaning, we recommend intervals from 6 to 12 months.
- **Venturi pump:** The maintenance of the pump should be done at the same time as that of the reaction pipe:
 - Drain the water out and dismantle the pump. Flush the pump housing and the needle wheel with clean water.
 - The same should be done with the **air injection nozzle**.

6. Failures

Failures may arise if:

- the ratio between supplied air and the water volume is not correct.

Cause:

The air injection nozzle is clogged or the pump chamber containing the needle wheel is dirty.

Action:

Dismantle the venturi pump, clean it thoroughly, carefully clean the air injection nozzle with a thin brush or blunt instrument and re-assemble the pump again.

- the venturi pump does not re-start after an interruption of the power supply.

Cause:

The water pressure is too high.

Action:

Let the water out up to the height of the pump to lower the water pressure. Re-start the pump.

7. Warranty

This product is warranted for 24 months after date of purchase on material and production defects by  **AQUA MEDIC**. Proof of purchase is required.

This warranty does not apply to units that are improperly installed, used for any other purpose than that intended or modified in any way.

 **AQUA MEDIC** is not liable for any consequential losses resulting from the use of this product.

We retain the right to alter the specification of this product at any time without prior notice.